



CATÁLOGO VASOS CRISTALINOS

www.mexcup.com.mx  

INDICE

VASOS	PAG.
PLÁSTICO CRISTALINOS	
12oz	3
16oz	4
20oz	5
24oz	6
32oz	7

VASOS DE PLÁSTICO CRISTALINOS

CLAVE	DESCRIPCIÓN	MAT	ÁREA DE IMPRESIÓN
CET12	CRISTALINO 12 - 14oz	PET	A: 5.5, L: 19

● Medidas en cm.

● Área del vaso ● Área de impresión

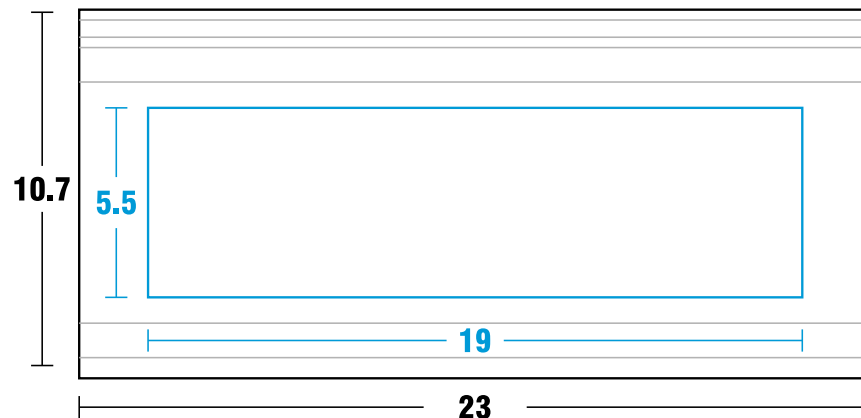
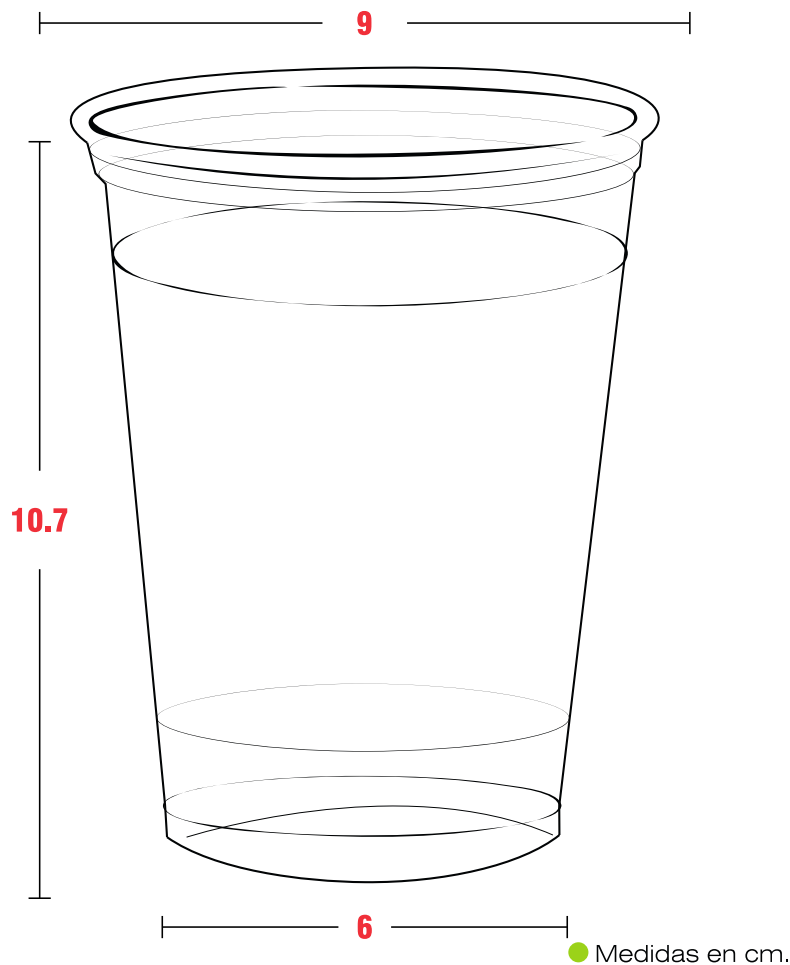

DIMENSIONES (CM) DS: 9.0, DI: 6.0, C: 23.0, A: 10.7

CLAVES:

DS: DIÁMETRO SUPERIOR
DI: DIÁMETRO INFERIOR

C: CIRCUNFERENCIA
A: ALTURA

L: LARGO

DESCRIPCIÓN DE TAPA:

TL12CET: Tapa Plana con respiradero

TPD90: Tapa Domo

TB12CET: Tapa con boquilla

MUESTRA



TAPA



TL12CET



TPD90



TB12CET

VASOS DE PLÁSTICO CRISTALINOS

CLAVE	DESCRIPCIÓN	MAT	ÁREA DE IMPRESIÓN
CET16	CRISTALINO 16oz	PET	A: 6.5, L: 19.5

● Medidas en cm.

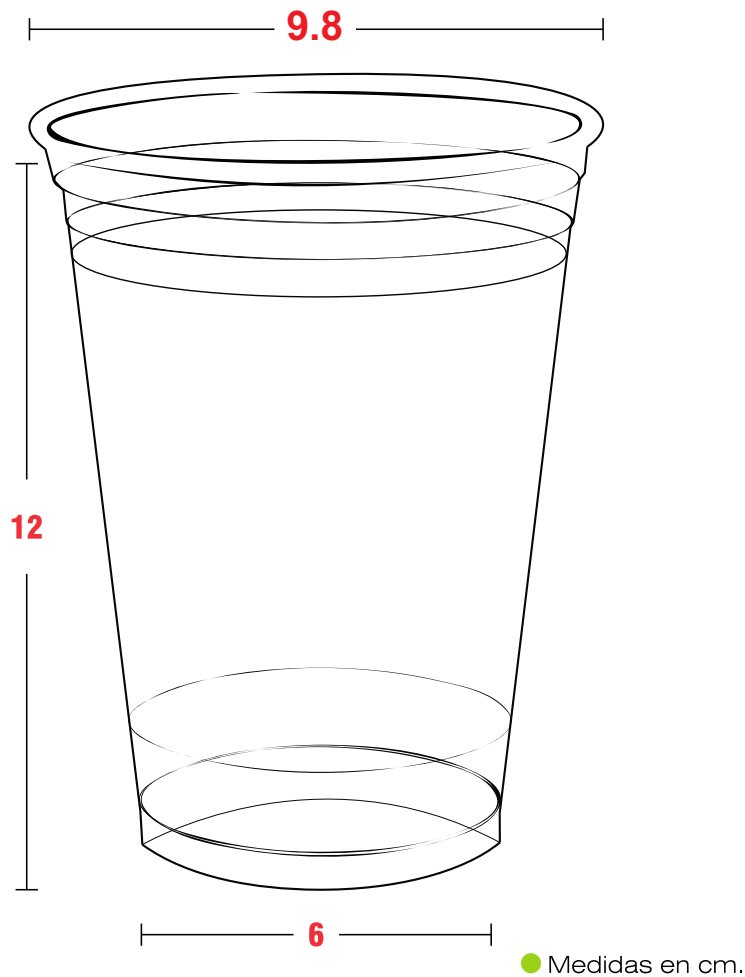

● Área del vaso ● Área de impresión

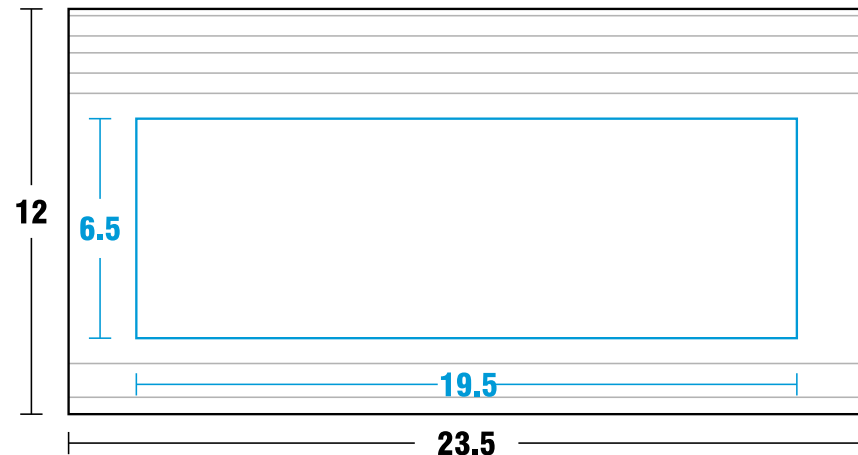

DESCRIPCIÓN DE TAPA:

MUESTRA

TL16CET: Tapa Plana con respiradero

TPD98: Tapa Domo

TB16CET: Tapa con boquilla



TAPA



TL16CET



TPD98



TB16CET

DIMENSIONES (CM) DS: 9.7, DI: 6.0, C: 23.5, A: 12.0

CLAVES:

DS: DIÁMETRO SUPERIOR
DI: DIÁMETRO INFERIOR

C: CIRCUNFERENCIA
A: ALTURA

L: LARGO

VASOS DE PLÁSTICO CRISTALINOS

CLAVE	DESCRIPCIÓN	MAT	ÁREA DE IMPRESIÓN
CET20	CRISTALINO 20oz	PET	A: 9.5, L: 21.5

● Medidas en cm.

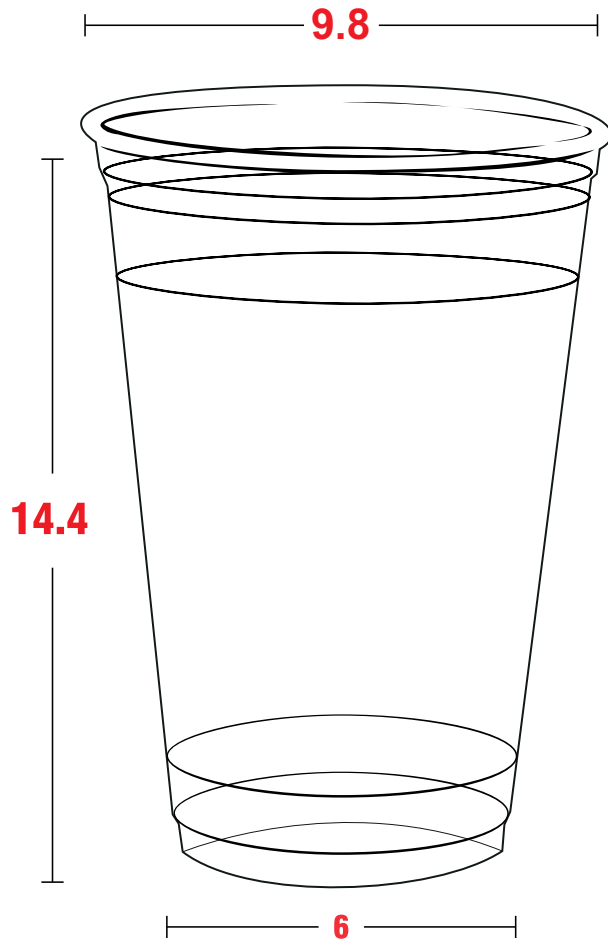

● Medidas en cm.

● Área del vaso ● Área de impresión

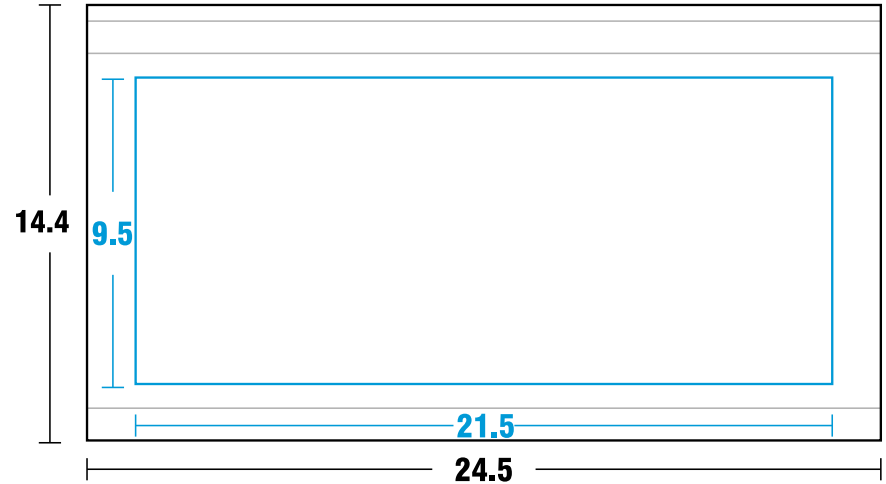

DESCRIPCIÓN DE TAPA:

MUESTRA

TL16CET: Tapa Plana con respiradero

TPD98: Tapa Domo

TB16CET: Tapa con boquilla



TAPA



TL16CET



TPD98



TB16CET

DIMENSIONES (CM) DS: 9.5, DI: 6.0, C: 24.5, A: 13.5

CLAVES:

DS: DIÁMETRO SUPERIOR
DI: DIÁMETRO INFERIOR

C: CIRCUNFERENCIA
A: ALTURA

L: LARGO

VASOS DE PLÁSTICO CRISTALINOS

CLAVE

DESCRIPCIÓN

MAT

ÁREA DE IMPRESIÓN

● Medidas en cm.

CET24

CRISTALINO 24oz

PET

A: 8, L: 23

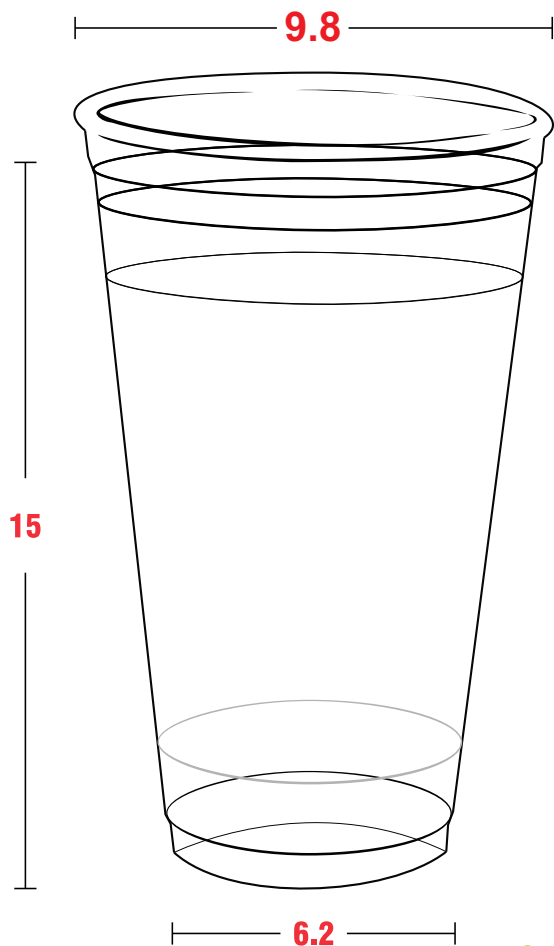

● Medidas en cm.

● Área del vaso ● Área de impresión

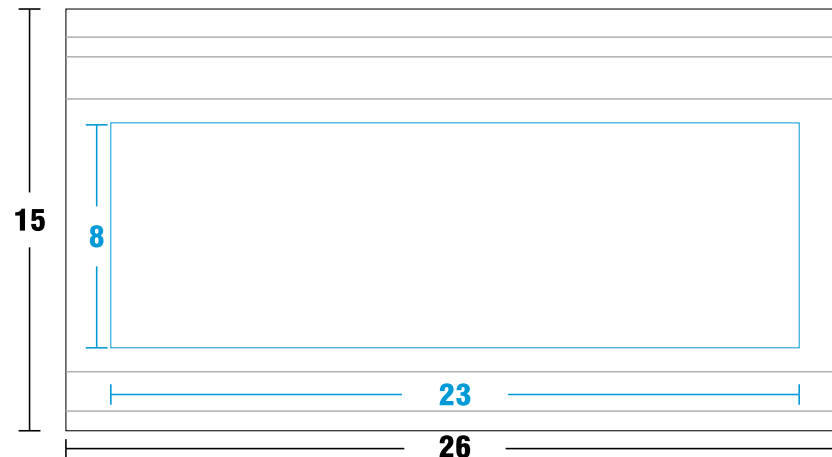

DESCRIPCIÓN DE TAPA:

MUESTRA

TL16CET: Tapa Plana con respiradero

TPD98: Tapa Domo

TB16CET: Tapa con boquilla



TAPA



TL16CET



TPD98



TB16CET

DIMENSIONES (CM) DS: 9.7, DI: 6.2, C: 26.0, A: 15.5

CLAVES:

DS: DIÁMETRO SUPERIOR
DI: DIÁMETRO INFERIOR

C: CIRCUNFERENCIA
A: ALTURA

L: LARGO

VASOS DE PLÁSTICO CRISTALINOS

CLAVE
CET32

DESCRIPCIÓN
CRISTALINO 32oz

MAT
PET

ÁREA DE IMPRESIÓN
A: 8, L: 23

● Medidas en cm.

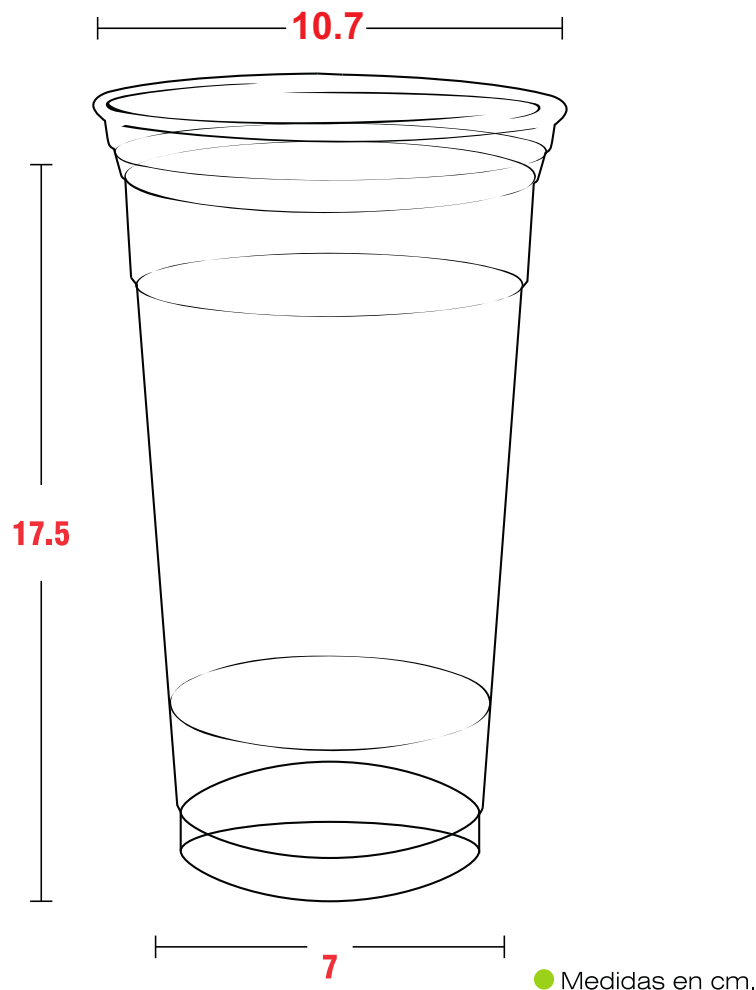

● Área del vaso ● Área de impresión

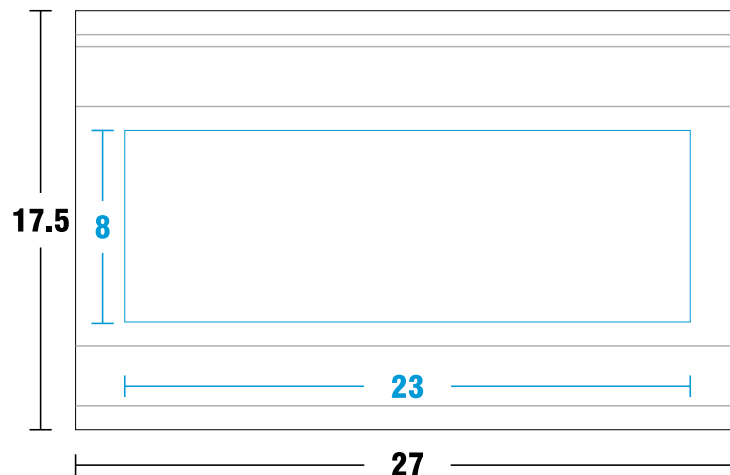

DESCRIPCIÓN DE TAPA:

MUESTRA

TL32CET: Tapa Plana con respiradero



TAPA



TL32CET

DIMENSIONES (CM) DS: 10.5, DI: 7, C: 27.0, A: 17.5

CLAVES:

DS: DIÁMETRO SUPERIOR
DI: DIÁMETRO INFERIOR

C: CIRCUNFERENCIA
A: ALTURA

L: LARGO